



## PIATTAFORMA PER LAVORO AEREO AUTOCARRATA

TRUCK-MOUNTED AERIAL LIFT WORK PLATFORM

HUBARBEITSBÜHNE AUF LKW

NACELLE ÉLÉVATRICE ARTICULÉE



# PNT200H

isoli@isoli.com | www.isoli.com







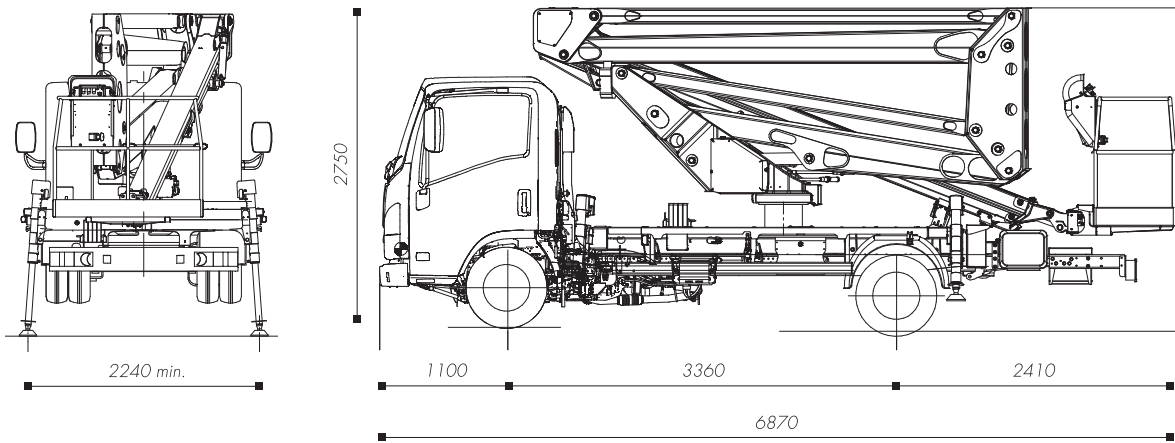



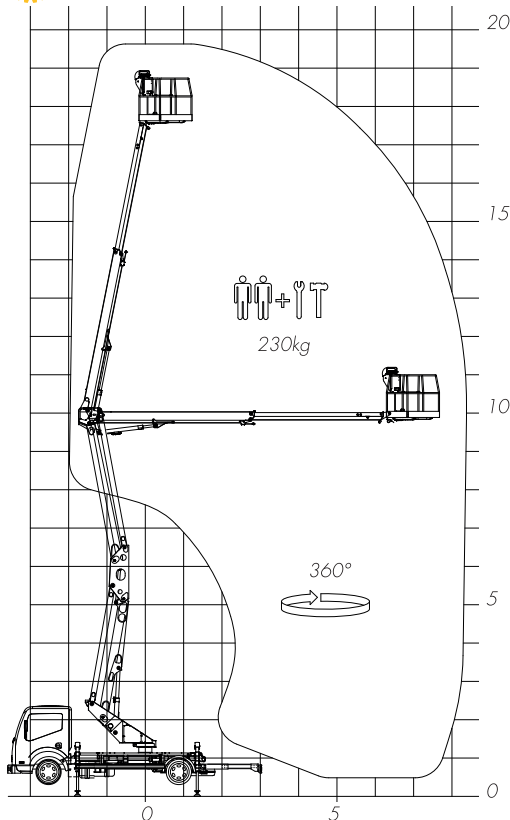



## DIMENSIONI / OVERALL DIMENSION / GESAMTABMESSUNGEN / DIMENSIONS [mm]



## DIAGRAMMA DI LAVORO / WORKING DIAGRAM / ARBEITSDIAGRAMM / SCHÉMA DE TRAVAIL [m]



CARATTERISTICHE TECNICHE / TECHNICAL FEATURES / TECHNISCHE EIGENSCHAFTEN / DETAILS TECHNIQUES

	<b>Altezza max. di lavoro</b> Max. working height Max. Arbeitshöhe Hauteur travail	19,7 m
	<b>Sbraccio max. di lavoro</b> Max. working boom extension Max. Reichweite Portée à hauteur maximale	8,5 m
	<b>Portata</b> Capacity Traglast Charge utile	230 Kg
	<b>N. operatori</b> N. operators Anzahl Personen N. opérateurs	2
	<b>Altezza piano calpestio</b> Walk-on surface height Korbbodenhöhe Hauteur plancher	17,9 m
	<b>Rotazione sovrastruttura</b> Upperstructure rotation Drehung Oberwagen Rotation tourelle	400°
	<b>Cesta</b> Basket Arbeitskorb Panier	Alluminio 1400x715x1115 mm Aluminium 1400x715x1115 mm Aluminium 1400x715x1115 mm Aluminium 1400x715x1115 mm
	<b>Stabilizzatori</b> Outriggers Abstützungen Stabilisation	<b>Verticale HH sagoma</b> Vertical stabilisation HH in folded position Vertikale Stabilisierung HH in gefalteter Position Verticale HH dans le gabarit
	<b>Comandi</b> Controls Steuerungen Commandes	<b>Elettroidraulici</b> Electro-hydraulic Elektrohydraulisch Electrohydrauliques